

Residual Current Transformers – Type A

Associated with DIRIS Digiware R-60 modules

new



Δ IC Ø 8 mm residual CT

Δ IC residual CT

WR residual CT

Δ IP-R residual CT

The solution for

- > Industries
- > Data centres



Strong points

- > A complete range
- > Optimum performances
- > High sensitivity
- > Clear alarm indication
- > Plug & play

Compliance with standards

- > IEC 62020
- > IEC 61869-1
- > ISO 14025



Create your project

- > Find the best DIRIS Digiware configuration:
www.meter-selector.com



Function

Residual Current Transformers enclose active conductors providing the differential summation of vector currents which enables the detection of leakage currents.

Solid core (Δ IC, WR and TFR series) or split core (Δ IP-R) are adapted to all cabling configurations, for both new and existing installations.

Residual CTs can be mounted on DIN-rail, on back-plate or directly on the cable to simplifying the integration into confined spaces with high integration constraints.

The T-10 RJ12 adaptor ensures the connection of the residual CT to the DIRIS Digiware R-60 module via an RJ12 cable, available in multiple lengths.

Advantages

A complete range

All dimensions and types are available for compatibility with busbar or cable configurations of all dimensions, for single-phase or three-phase applications.

Optimum performances

Thanks to a patented innovation, the conductors are perfectly centered in the residual CT to ensure accurate measurement and enhanced immunity to network interferences. It also enables direct mounting of the residual CT onto the cable.

High sensitivity

Socomec residual CTs are able to measure leakage currents starting at 3 mA allowing to detect insulation degradations early on.

Clear alarm indication

The T-10 RJ12 adaptor integrates an alarm LED to quickly locate RCM alarms inside electrical panels.

Plug & Play

- Direct mechanical and electrical connections to the residual current transformer.
- RJ12 connection to the DIRIS Digiware R-60 for simplified integration of the Digiware system.

Residual Current Transformers – Type A

Associated with DIRIS Digiware R-60 modules

Connections

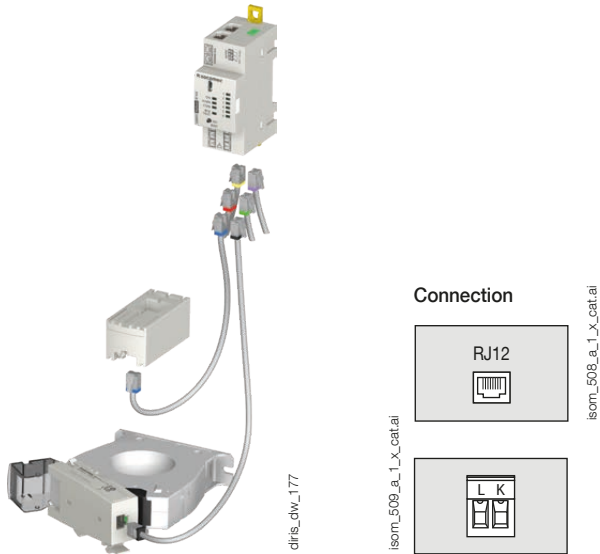

T-10 adaptor



1. Clip to mechanically and electrically connect to the Δ IC residual CT.
2. Alarm LED. Lights if the high threshold RCM alarm is active or flashes if there is a connection issue with the residual CT.
3. Connection base to the Δ IC residual CT (supplied with 2-pin removable terminal block for remote connection).
4. DIN rail mounting clip.
5. RJ12 connection to DIRIS Digiware R-60.

Dimensions (mm)

T-10 RJ12 adaptor

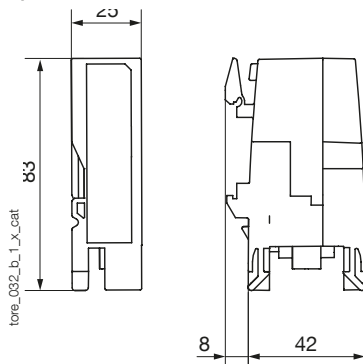

WR series solid core rectangular residual current transformers

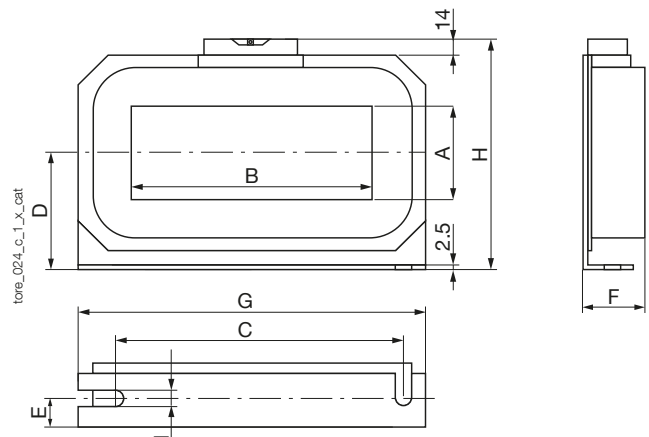

Δ IC solid core residual current transformers

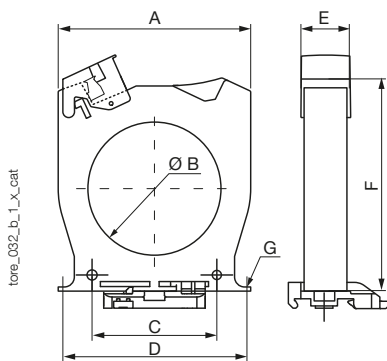

Type	A (mm)	B (mm)	C (mm)	D (mm)	E (mm)	F (mm)	G (mm)	Weight (kg)
Δ IC \varnothing 15	53	17,3	27,8	50	26	81	M4	0,10
Δ IC \varnothing 30	92	30	50	85	26	103,5	M4	0,13
Δ IC \varnothing 50	102,5	50	50	90	26	125	M5	0,18
Δ IC \varnothing 80	116	80	75	105	26	142,5	M5	0,22
Δ IC \varnothing 120	163	120	100	150	26	182,5	M6	0,38
Δ IC \varnothing 200	253	200	150	175 x 41,2	51	274	M6	0,88
Δ IC \varnothing 300	370	300	200	250 x 41,5	50	390	M6	1,72

- A. Width
- B. Diameter
- C. Distance between fixing centres
- D. Distance between rear fixing brackets
- E. Depth
- F. Height
- G. Diameter of fixing screws

Type	A (mm)	B (mm)	C (mm)	D (mm)	E (mm)	F (mm)	G (mm)	H (mm)	I (mm)	Weight (kg)
WR 70 x 175	70	175	225	85	22	46	261	176	7.5	2.9
WR 115 x 305	115	305	360	116	25	55	402	240	8	6.3
WR 150 x 350	150	350	415	140	28	55	460	285	8	8.2

- A. Window width
- B. Window length
- C. Spacers
- D. Half-height
- E. Depth of mounting spacers
- F. Depth
- G. Width
- H. Height
- I. Width of oblong fixing holes

Δ IC \varnothing 8 mm solid core residual current transformers

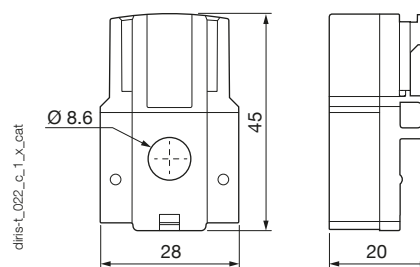

Residual Current Transformers – Type A

Associated with DIRIS Digiware R-60 modules

Dimensions (mm) (continued)

TFR rectangular solid core residual current transformer

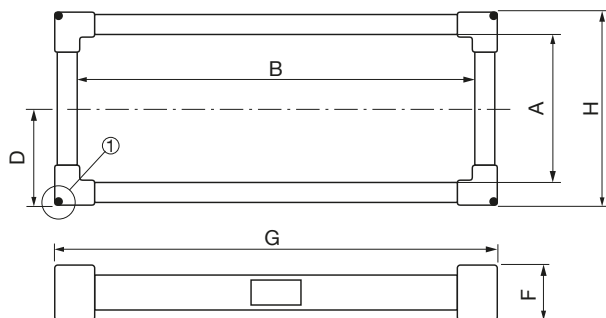

① Additional mounting details

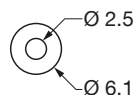

- A. Window width
- B. Window length
- D. Half-height
- F. Depth
- G. Width
- H. Height

Type	A (mm)	B (mm)	D (mm)	F (mm)	G (mm)	H (mm)	Weight (kg)
TFR 200 x 500	200	500	140	62	585	285	7.2

ΔIP-R split core residual current transformers

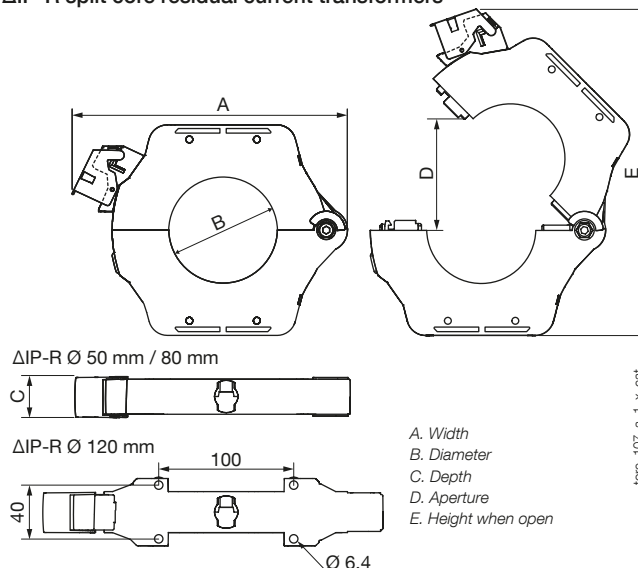

ΔIP-R Ø 50 mm / 80 mm



ΔIP-R Ø 120 mm

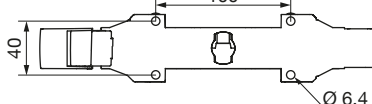

- A. Width
- B. Diameter
- C. Depth
- D. Aperture
- E. Height when open

Type	A (mm)	B (mm)	C (mm)	D (mm)	E (mm)	Weight (kg)
ΔIP-R Ø 50	160	49	30	77	200	
ΔIP-R Ø 80	204	79	30	108	260	0,85
ΔIP-R Ø 120	252	119	30	149	328	1,5

Accessories for residual CTs



T-10 RJ12 adaptor for residual current transformers	Reference
T-10	4829 0620

The T-10 adaptor can be mounted directly on ΔIC residual CTs, for diameters > 30 mm, and ΔIP-R residual CTs.



Flexible cable centering accessory	Ø (mm)	Reference
Flexible cable centering accessory	30	4950 0011
Flexible cable centering accessory	50	4950 0012
Flexible cable centering accessory	80	4950 0013
Flexible cable centering accessory	120	4950 0014

Only for ΔIC and ΔIP-R.



Metal mounting bracket	Ø (mm)	Reference
Metal mounting bracket	30	4950 0001
Metal mounting bracket	50	4950 0002
Metal mounting bracket	80	4950 0003
Metal mounting bracket	120	4950 0003
Metal mounting bracket	200	4950 0004
Metal mounting bracket	300	4950 0005

Only for ΔIC and ΔIP-R.



Screw-in/out terminal block	Reference
Screw-in/out terminal block (provided with ΔIC and ΔIP-R)	4950 0041

Only for ΔIC and ΔIP-R.



DIN-rail clip	Reference
DIN-rail clip (provided with ΔIP-R)	4950 0031

Only for ΔIC and ΔIP-R.

Residual Current Transformers – Type A

Associated with DIRIS Digiware R-60 modules

Technical characteristics

General characteristics	$\Delta IC \text{ } \varnothing 8 \text{ mm}$	$\Delta IC \text{ } \varnothing 15 - 300 \text{ mm}$	$\Delta IP-R \text{ series}$	WR & TFR series
RCM type IEC 62020	Type A			
Connection type	Socomec RJ12 cables	Socomec RJ12 cables via T-10 adaptor		
Electrical characteristics				
Insulation coordination	According to IEC 60664-1			
Measurement range	3 mA - 3A			
Accuracy class	1	3		5
Winding ratio	200 / 1	600 / 1		
Max. operating voltage	300 VAC	720 VAC	720 VAC	690 VAC
Rated impulse voltage	6.4 kV	8 kV		
Rated withstand voltage	3 kV			
Operating temperature	-10 ... +55 °C	-40 ... +80 °C	-40 ... +80 °C	-10 ... +55 °C
Flammability class	UL94V-0			

References

$\Delta IC^{(1)}$ solid core residual CTs	\varnothing (mm)	Reference
$\Delta IC \text{ } \varnothing 8$	8	4829 0520
$\Delta IC \text{ } \varnothing 15$	15	4950 6015
$\Delta IC \text{ } \varnothing 30$	30	4950 6030
$\Delta IC \text{ } \varnothing 50$	50	4950 6050
$\Delta IC \text{ } \varnothing 80$	80	4950 6080
$\Delta IC \text{ } \varnothing 120$	120	4950 6120
$\Delta IC \text{ } \varnothing 200$	200	4950 6200
$\Delta IC \text{ } \varnothing 300$	300	4950 6300

WR and TFR-series rectangular solid core residual CTs	\varnothing (mm)	Reference
WR 70 x 175	70 x 175	4795 0717
WR 115 x 305	115 x 305	4795 1130
WR 150 x 350	150 x 350	4795 1535
TFR 200 x 500	200 x 500	4795 2050

$\Delta IP-R^{(1)}$ series split core residual CTs	\varnothing (mm)	Reference
$\Delta IP-R \text{ } \varnothing 50$	50	4750 6051
$\Delta IP-R \text{ } \varnothing 80$	80	4750 6081
$\Delta IP-R \text{ } \varnothing 120$	120	4750 6121

(1) ΔIC and $\Delta IP-R$ residual CTs come with a sealable protective cover, a push-in terminal block (except 15mm with fixed terminal block and without cover), and a DIN rail mounting accessory for diameters below 200 mm.

RJ12 connection cables	Cable length (m)									
	0.1	0.2	0.3	0.5	1	2	3	5	10	50 m reel + 100 connectors
Number of cables	Reference	Reference	Reference	Reference	Reference	Reference	Reference	Reference	Reference	Reference
1	-	-	-	-	-	-	-	4829 0602	4829 0603	4829 0601
3	4829 0580	4829 0581	4829 0582	4829 0595	4829 0583	4829 0584	4829 0606	-	-	-
4	-	-	-	4829 0596	4829 0588	4829 0589	-	-	-	-
6	4829 0590	4829 0591	4829 0592	4829 0597	4829 0593	4829 0594	-	-	-	-

Expert Services

Require integration onto your network?

No problem for our "Expert Services" team. They will fully integrate all your SOCOMEC devices, **audit** your system, **commission** selected equipment and **train** your staff on its use.

For further information, please contact your nearest SOCOMEC branch.